

Navrtka klizna SM

PREGLED

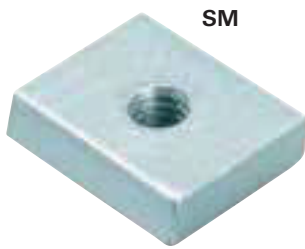

SM

Svojstva:

Materijal	Čelik S235 JR (materijal br. 1.0037) prema DIN EN 10025
Pocinkovanje	galvanski pocinkovano, min. 5 µm

OPIS PROIZVODA

- Pričvrtni element za MS šine.

Prednosti/koristi

- Jednostavna montaža i poravnanje u šini.

MONTAŽA

Uputstvo za montažu

- Nakon poravnanja navojnu ploču bi trebalo osigurati maticom.

TEHNIČKI PODACI

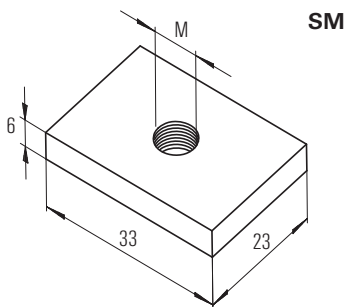

Tip	Br. art.	Pakovanje	Navoj M
		[Komada]	
SM 38 M 8	079600	50	M 8
SM 38 M 10	079601	50	M 10

TERETI

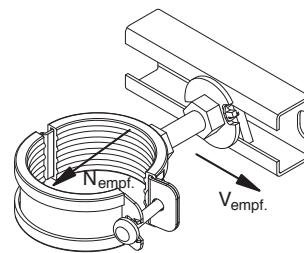

Tip	Profil	Maks. prihv. centralno vučno opterećenje	Maks. prihv. poprečno vučno opterećenje	Momenat pritezanja [Nm]
		N _{empt.} [kN]	V _{empt.} [kN]	
SM 38 M8	38/40	6,0	0,8	15,0
	40/60	7,5	0,8	15,0
SM 38 M10	38/40	6,0	1,0	25,0
	40/60	7,5	1,0	25,0